

TEST REPORT

Report No.: E1117.01-109-44

Rendered to:

FAIRFIELD METAL, LLC
Fairfield, New Jersey

PRODUCT TYPE: AMC Panel System (Dry Seal)
SERIES/MODEL: RFM (Rainscreen)

Title	Summary of Results
Design Pressure	+3840 Pa (+80.20 psf) -2880 Pa (-60.15 psf)
Air Infiltration	<0.1 L/s/m ² (<0.01 cfm/ft ²)
Water Penetration Resistance Test Pressure	720 Pa (15.04 psf)

Reference must be made to Report No. E1117.01-109-44, dated 12/04/14 for complete test specimen description and detailed test results.



1.0 Report Issued To: Fairfield Metal
9 Audrey Place
Fairfield, New Jersey 07004

2.0 Test Laboratory: Architectural Testing, Inc.
130 Derry Court
York, Pennsylvania 17406-8405
717-764-7700

3.0 Project Summary:

3.1 Product Type: AMC Panel System (Dry Seal)

3.2 Series/Model: RFM (Rainscreen)

3.3 Compliance Statement: Results obtained are tested values and were secured by using the designated test method(s). Test specimen description and results are reported herein.

3.4 Test Dates: 11/12/2014 - 11/14/2014

3.5 Test Record Retention End Date: All test records for this report will be retained until November 14, 2018.

3.6 Test Location: Architectural Testing, Inc. test facility in York, Pennsylvania.

3.7 Test Sample Source: The test specimen was provided by the client. Representative samples of the test specimen(s) will be retained by Architectural Testing for a minimum of four years from the test completion date.

3.8 Drawing Reference: The test specimen drawings have been reviewed by Architectural Testing and are representative of the test specimen(s) reported herein. Test specimen construction was verified by Architectural Testing per the drawings located in Appendix B. Any deviations are documented herein or on the drawings.

3.9 List of Official Observers:

<u>Name</u>	<u>Company</u>
Ryan Hunt	Fairfield Metal, LLC
Michael D. Stremmel, P.E.	Architectural Testing, Inc.
Scott Gill	Architectural Testing, Inc.

4.0 Test Method(s):

ASTM E 283-04, *Test Method for Determining Rate of Airflow Through Exterior Windows, Curtain Walls and Doors Under Specified Pressure Differences Across the Specimen.*

ASTM E 330-02, *Test Method for Structural Performance of Exterior Windows, Curtain Walls and Doors by Uniform Static Air Pressure Difference.*

ASTM E 331-00, *Test Method for Water Penetration of Exterior Windows, Curtain Walls and Doors by Uniform Static Air Pressure Difference.*

AAMA 501-1-05, *Standard Test Method for Water Penetration of Windows, Curtin Walls and Doors using Dynamic Pressure.*

5.0 Test Specimen Description:

5.1 Product Sizes:

Overall Area: 5.9 m ² (64.0 ft ²)	Width		Height	
	millimeters	inches	millimeters	inches
Overall size	2438	96	2438	96
Top panel	2426	95-1/2	1207	47-1/2
Left bottom panel	1207	47-1/2	1207	47-1/2
Right bottom panel	1207	47-1/2	1207	47-1/2

5.2 Base Wall Construction: The test wall was fabricated with 16 gauge, 6" galvanized steel studs, spaced 16" on center. The steel studs were secured at each end to the top and bottom 16 gauge steel track using #6 x 3/4" long hex head self-tapping screws. The stud wall was sheathed with 5/8" thick DensGlass™ which was secured to the studs with #6 x 1-1/4" long flat head self-tapping screws. The DensGlass™ was covered with a rubberized peel-and-stick air-water barrier. The wall utilized a nominal 2x8 Spruce-Pine-Fir wood wrap around the perimeter, secured to the steel studs with #10 x 3" long flat head self-tapping screws.

5.0 Test Specimen Description: (Continued)

5.3 Panel Construction: The test specimen was constructed of three aluminum composite panels that were 4 mm (0.157") thick. The panels were constructed with a 0.120" thick plastic core and two 0.020" thick aluminum interior and exterior skins, adhered to the plastic core. A 90° bend was utilized on all four sides of the panels, resulting in a 1" long return leg. The corners utilized a 1/2" wide, 1" by 1" aluminum angle to secure the corners, secured to each panel leg with one 1/8" diameter pop rivet. All panel edges utilized aluminum extrusions which were secured to the panels with 1/8" diameter rivets, spaced 12" on center. The bottom edge of each panel utilized two 1/2" long by 3/16" wide weepslots with open-cell foam behind the weep opening, located 2" from each end.

5.4 Reinforcement: The panels utilized "I" shaped extruded aluminum reinforcement. The reinforcement was located at the midspan of each panel and was secured to the backside of the panel with structural sealant.

5.5 Panel Installation: The panels were installed in a bottom to top and left to right order. The panels were attached to the stud wall using the aluminum extrusions on the panels. The extrusions were secured to the steel stud wall with #10 x 2" hex head self-tapping screws, spaced 16" on center into each stud. The panel joints utilized an aluminum extrusion that was slid into the panel extrusions. The joint extrusion was secured to the stud wall with #10 x 2" hex head self-tapping screws, spaced 16" on center into each stud. All panel joints utilized an ACM reveal strip that was slid into the slots on the panel perimeter extrusions. The perimeter of the wall system was sealed to the wood buck with butyl sealant.

6.0 Test Results: The temperature during testing was 19°C (66°F). The results are tabulated as follows:

Title of Test	Results	Allowed	Note
Air Leakage, per ASTM E 283 at 75 Pa (1.6 psf)	<0.1 L/s/m ² (<0.01 cfm/ft ²)	N/A	
Air Leakage, per ASTM E 283 at 300 Pa (6.2 psf)	<0.1 L/s/m ² (<0.01 cfm/ft ²)	N/A	
Water Penetration, per ASTM E 547 and ASTM E 331 at 720 Pa (15.04 psf)	Pass	No leakage	
Dynamic Water Penetration per AAMA 501.1 at 720 Pa (15.04 psf)	Pass	No leakage	
Uniform Load Deflection, per ASTM E 330 Deflections taken at horizontal joint between studs +3840 Pa (+80.20 psf) -2880 Pa (-60.15 psf)	0.5 mm (0.02") 0.3 mm (0.01")	N/A	1, 2
Uniform Load Structural, per ASTM E 330 Permanent sets taken at horizontal joint between studs +5760 Pa (+120.30 psf) -4320 Pa (-90.23 psf)	<0.3 mm (<0.01") 0.3 mm (0.01")	N/A	1, 2

General Note: All testing was performed in accordance with the referenced standard(s).

Note 1: Loads were held for 10 seconds.

Note 2: Tape and film were not used to seal against air leakage during structural testing.



Architectural Testing will service this report for the entire test record retention period. Test records that are retained such as detailed drawings, datasheets, representative samples of test specimens, or other pertinent project documentation will be retained by Architectural Testing, Inc. for the entire test record retention period.

This report does not constitute certification of this product nor an opinion or endorsement by this laboratory. It is the exclusive property of the client so named herein and relates only to the specimen(s) tested. This report may not be reproduced, except in full, without the written approval of Architectural Testing, Inc.

For ARCHITECTURAL TESTING, Inc.

Scott Gill
Senior Technician

Michael D. Stremmel, P.E.
Senior Project Engineer

SG:asm

Attachments (pages): This report is complete only when all attachments listed are included.

Appendix-A: Photograph (1)

Appendix-B: Drawings (5)

Revision Log

<u>Rev. #</u>	<u>Date</u>	<u>Page(s)</u>	<u>Revision(s)</u>
1	12/04/14	Summary page, Page 1	Changed series/model from CFM to RFM (Rainscreen)

Appendix A
Photograph



Photo No. 1
View of Tested Wall Assembly



Architectural Testing

Test Report No.: E1117.01-109-44

Revision 1: 12/04/14

Report Date: 12/04/14

Appendix B

Drawings

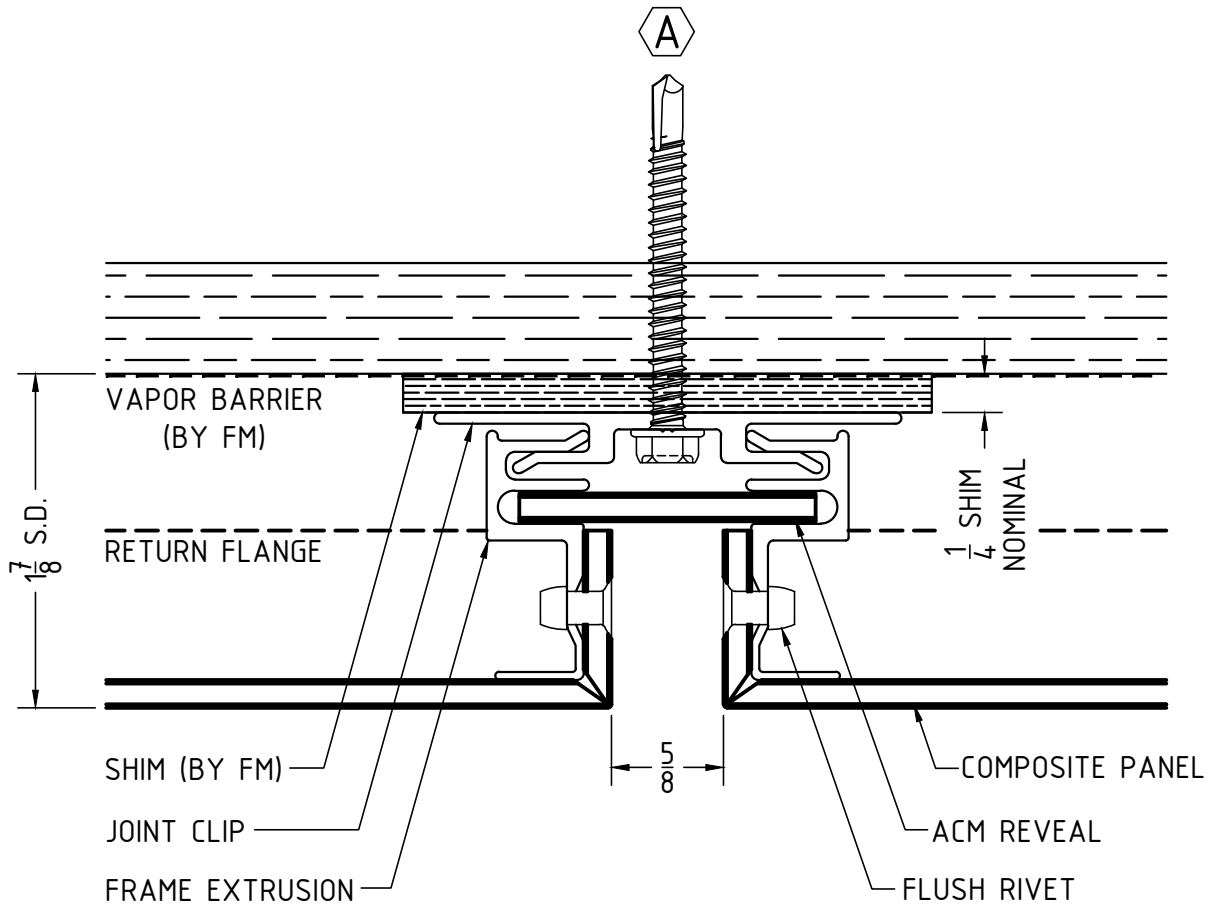

PANEL FASTENERS

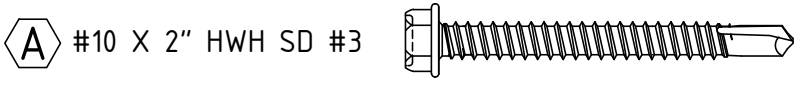

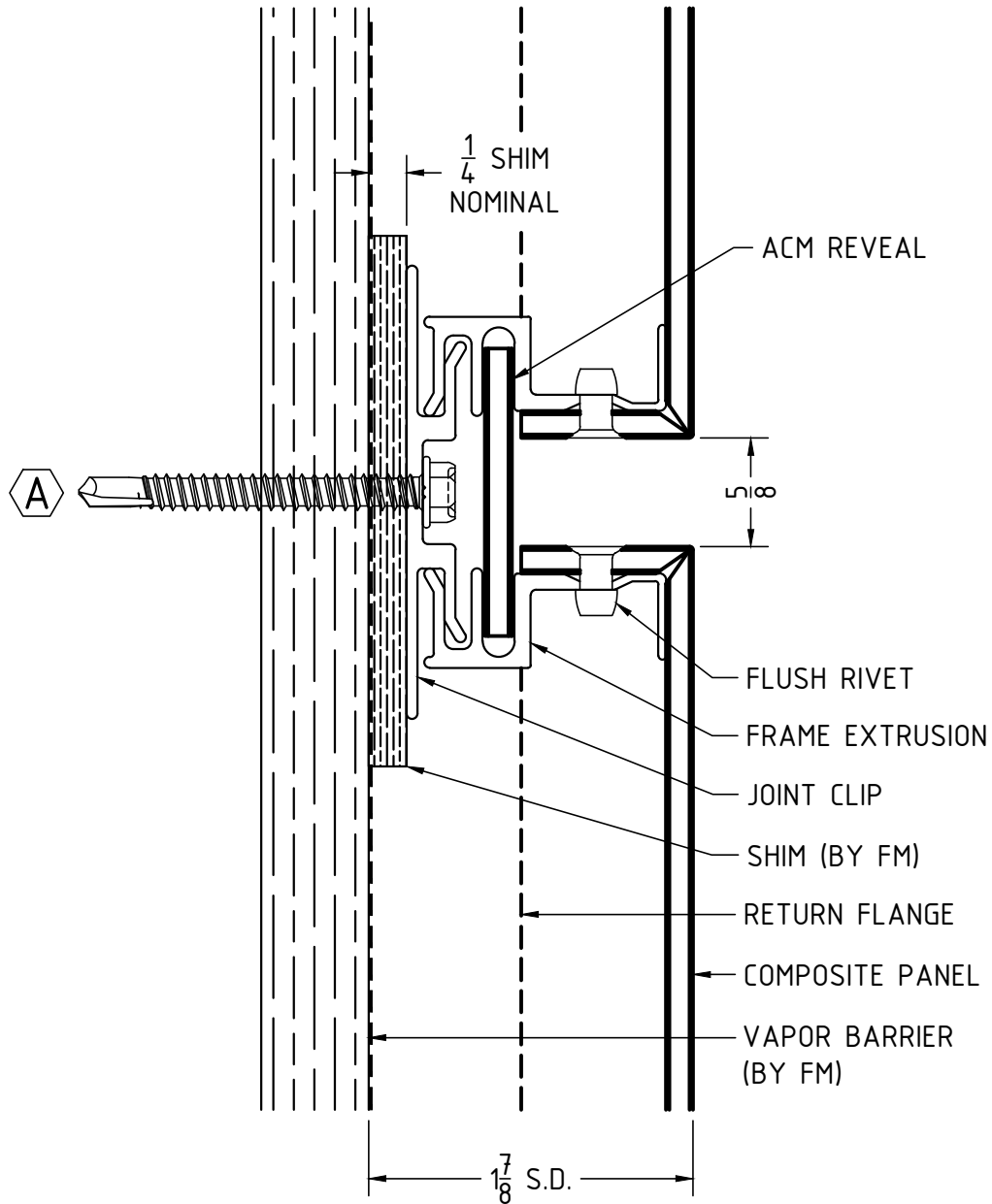

PANEL FASTENERS



Fairfield Metal
 9 Audrey Place, Fairfield, NJ 07004
 Phone: 973-276-8440
 www.fairfieldmetal.com

Project Name:
 RFM-HORIZONTAL JOINT DETAIL

Drawing No.
 RFM-HJ1

Drawn By: BJ

Scale: 1:1

Date: 03.05.2014

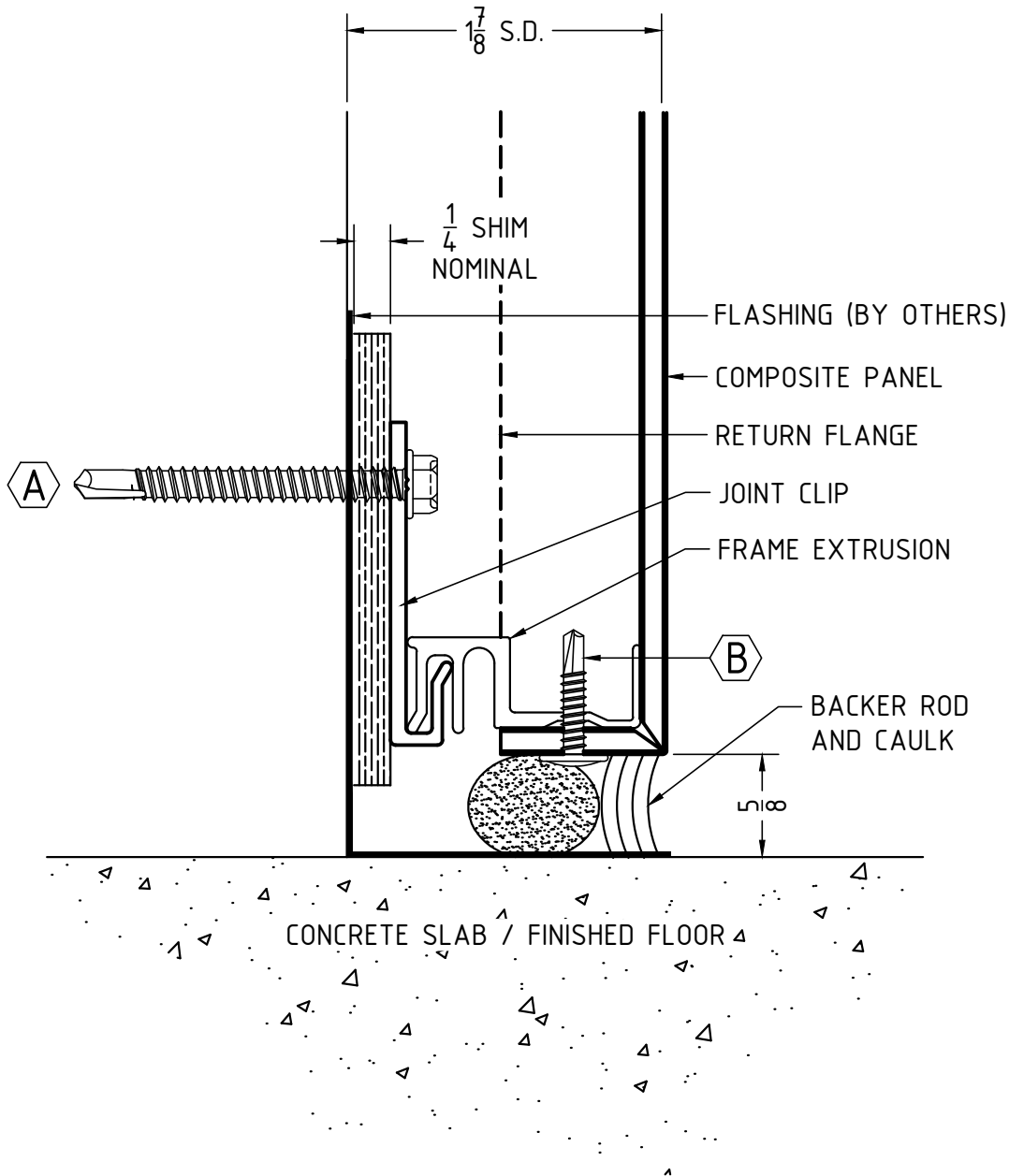

PANEL FASTENERS

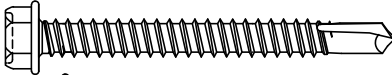
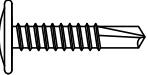
- A** #10 X 2" HWH SD #3 
- B** #10-16X3/4" PWH SDS #3 



Fairfield Metal
 9 Audrey Place, Fairfield, NJ 07004
 Phone: 973-276-8440
 www.fairfieldmetal.com



Project Name:
 RFM-BASE DETAIL (TYPE A)

Drawing No.
 RFM-BD1

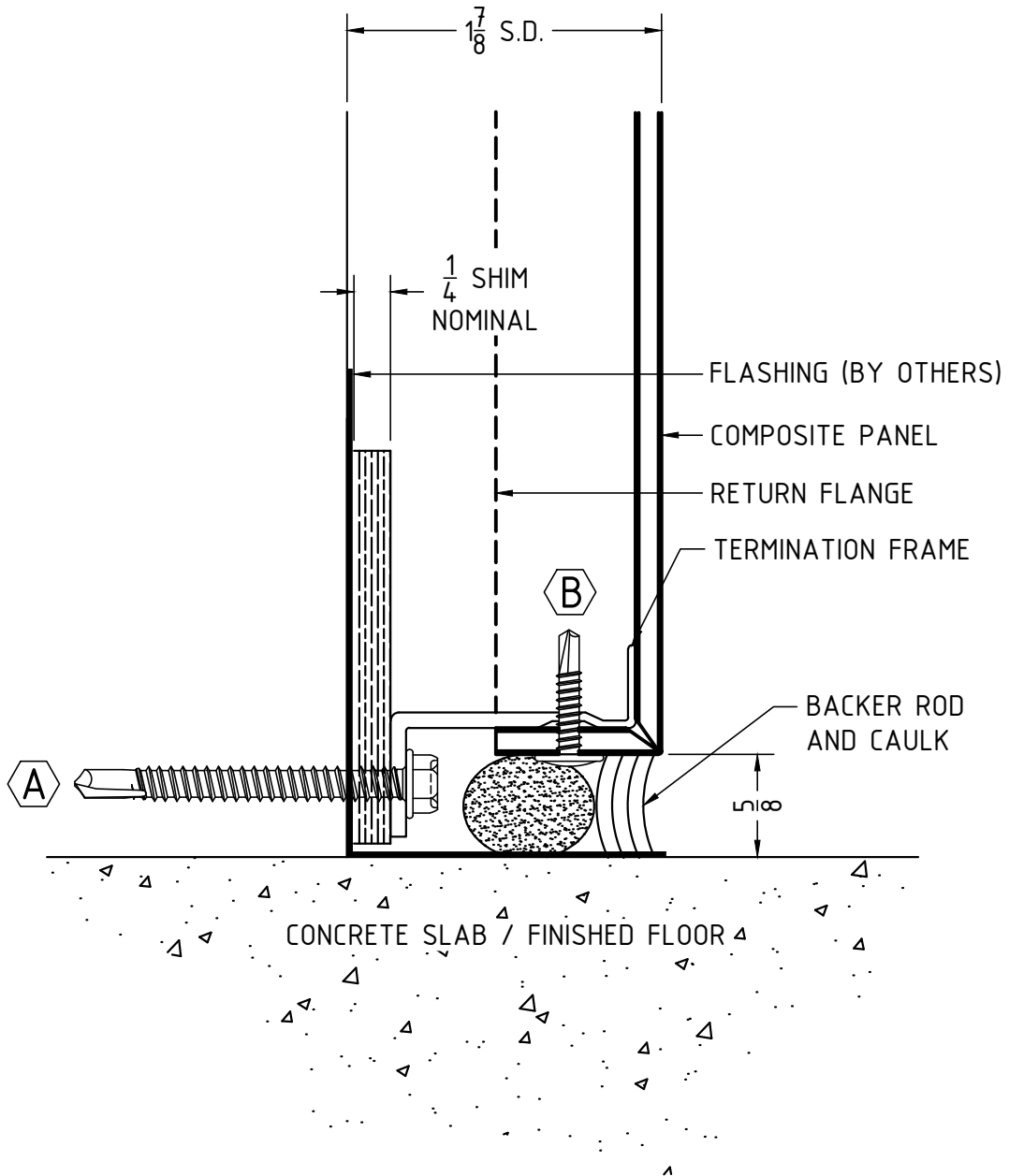
Drawn By: BJ Scale: 1:1 Date: 03.05.2014

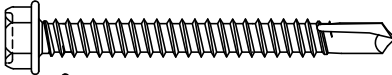

PANEL FASTENERS

-  #10 X 2" HWH SD #3 
-  #10-16X3/4" PWH SDS #3 



Fairfield Metal
 9 Audrey Place, Fairfield, NJ 07004
 Phone: 973-276-8440
 www.fairfieldmetal.com

Project Name:
 RFM-BASE DETAIL (TYPE B)

Drawing No.
 RFM-BD2

Drawn By: BJ

Scale: 1:1

Date: 03.05.2014

SUBSTRATE

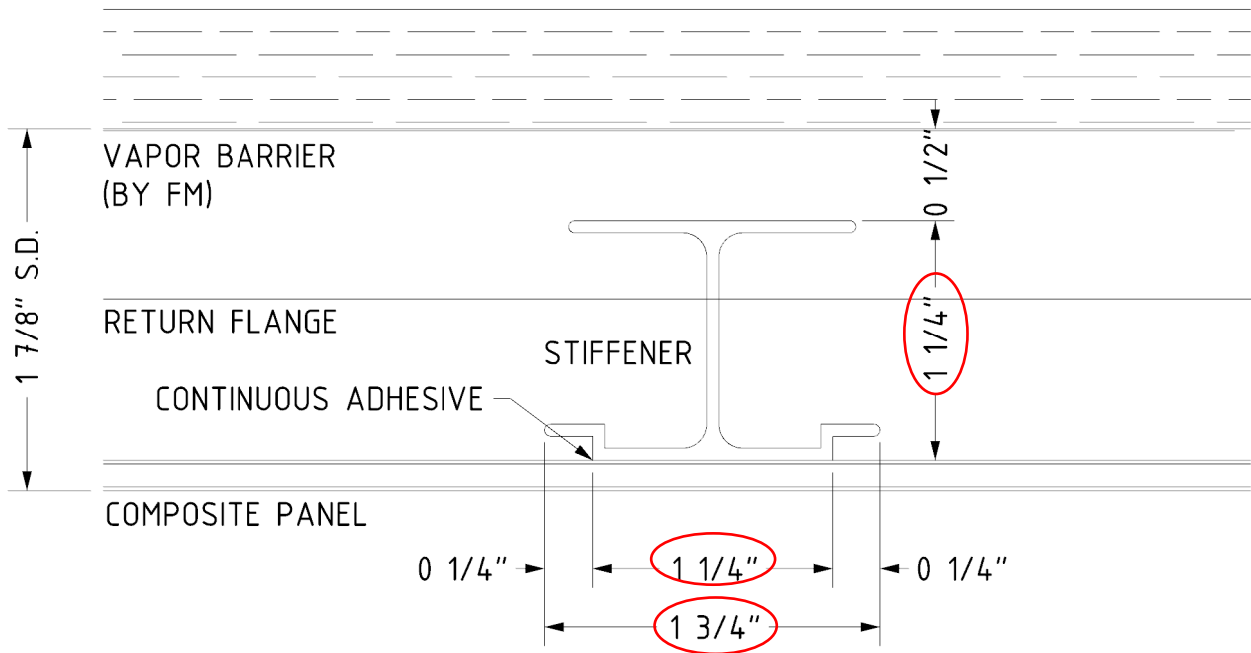

Report #: E1117.01-109-44
 Date: 12/02/14
 Verified by: *Scott Hill*

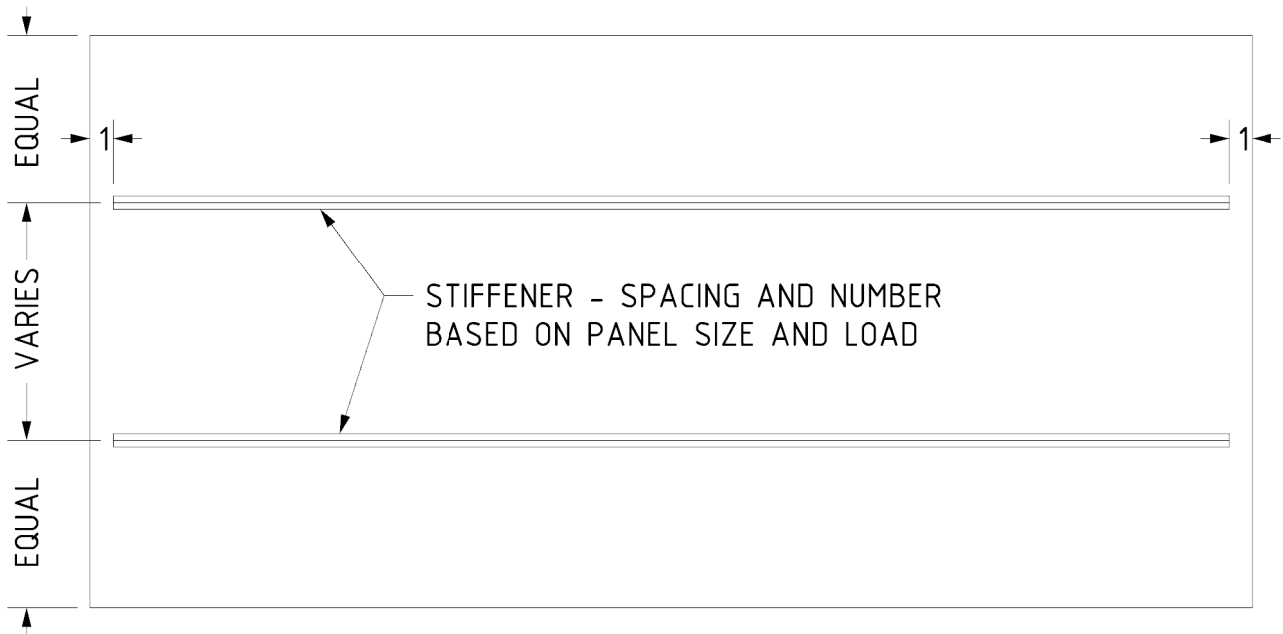

Fairfield Metal
 9 Audrey Place, Fairfield, NJ 07004
 Phone: 973-276-8440
 www.fairfieldmetal.com

Project Name:
 RFM RAINSCREEN STIFFENERS

Drawing No.

Drawn By: BJ Scale: 1:1 Date: 11.21.2014